

MODEL No.	DESCRIPTION:
7290T	Flash-Bang Training Body – Blue with Left Handed Thread
	Revision E 6/21

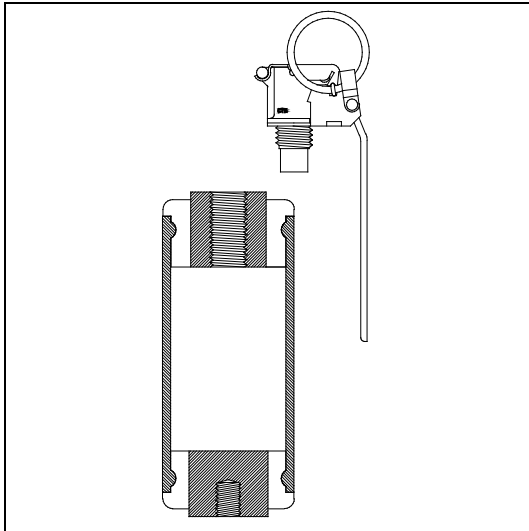

NOT TO SCALE

**WARNING:** CSI manufactures a variety of CTS less lethal products which are under pressure, pyrotechnic, incendiary, emit projectiles, generate smoke, or are explosive in nature. When used in accordance with CTS training guidelines and the individual agency's policy, they are intended to cause varying degrees of pain and injury, which are temporary. These products are restricted to law enforcement, corrections, and military personnel and are used to gain compliance, disperse crowds, restore order, or temporarily incapacitate dangerous persons. In rare circumstances, if used incorrectly, CTS less-lethal products may cause damage to property, serious bodily injury or death. Therefore, any person using the force option depicted on this page should receive proper training to ensure the safest and most effective use.

## PHYSICAL & OPERATIONAL

Type	Noise-Flash Diversion Device
Material	Steel - Black Chromate/Azure Blue Paint
Diameter	2.0" (50.8 mm)
Length	4.90" (124.4 mm)
Weight	560 gm
Blast Ports	10 on top – 10 on bottom
Fuze Type	Model 201 High-Output
Fuze Delay	1.5 +/- 0.3 sec. Average
Reloadable	Yes
Warranty	5 Years from Shipment Date

All specifications are average and are subject to change without notice.  
All performance specifications are based on testing conducted in Jamestown, PA USA,  
At an elevation of 1,058 feet above sea level at ambient temperature conditions.

## SHIPPING INFORMATION

Proper Shipping Name	Metal Parts
UN Number	N/A
Hazard Class	1 Piece
Labels Required	N/A
Quantity Per Package	2lbs.
Total Package Weight	N/A
Package Type	Fiberboard Box
Package Dimensions	12" x 9" x 7"

**\*\*\*CAUTION:** The deployment of any non-bursting canister devices onto soft, wet surfaces, such as mud, wet dirt and wet and dry sand may cause blast ports to become blocked, potentially causing the devices to launch and become a hazardous projectile.